

Standard Ethernet interface as an Embedded Communication Network for controlling and monitoring the devices.

Rajitha
Electronics and Communication Engineering
jayamuki College of Engineering
Warangal, India

Sandhya Rani (Asoc. Professor)
Electronics and Communication Engineering
jayamuki College of Engineering
Warangal, India.

Abstract—Web access functionality is embedded in a device to enable low cost widely accessible and enhanced user interface functions for the device. A web server in the device provides access to the user interface functions for the device through a device web page. A web server can be embedded into any appliance and connected to the Internet so the appliance can be monitored and controlled from remote places through the browser in a desktop

I. INTRODUCTION

This technique is to control the devices or equipment's from the remote place through a web page. Here all the devices, which are to be controlled, are connected to the relays (acts as switches) on the web server circuit board. The web-server circuit is connected to LAN or Internet. The client or a person on the PC is also connected to same LAN or Internet. By typing the IP-address of LAN on the web browser, the user gets a web page on screen; this page contains all the information about the status of the devices. The user can also control the devices interfaced to the web server by pressing a button provided in the web

The Block diagram shown in the fig 1 gives an overview of the interconnection between various devices in the design. The resources of the Micro Controller are used in such a way that simultaneous processing of information from the various sensors and also to send/receive data over the internet via the Ethernet Controller is made possible. The full 8 - bit operation of both the Micro Controller and the Ethernet Controller ensures no queuing up of data received from the internet. This is also complemented by the high speeds at which both the devices operate

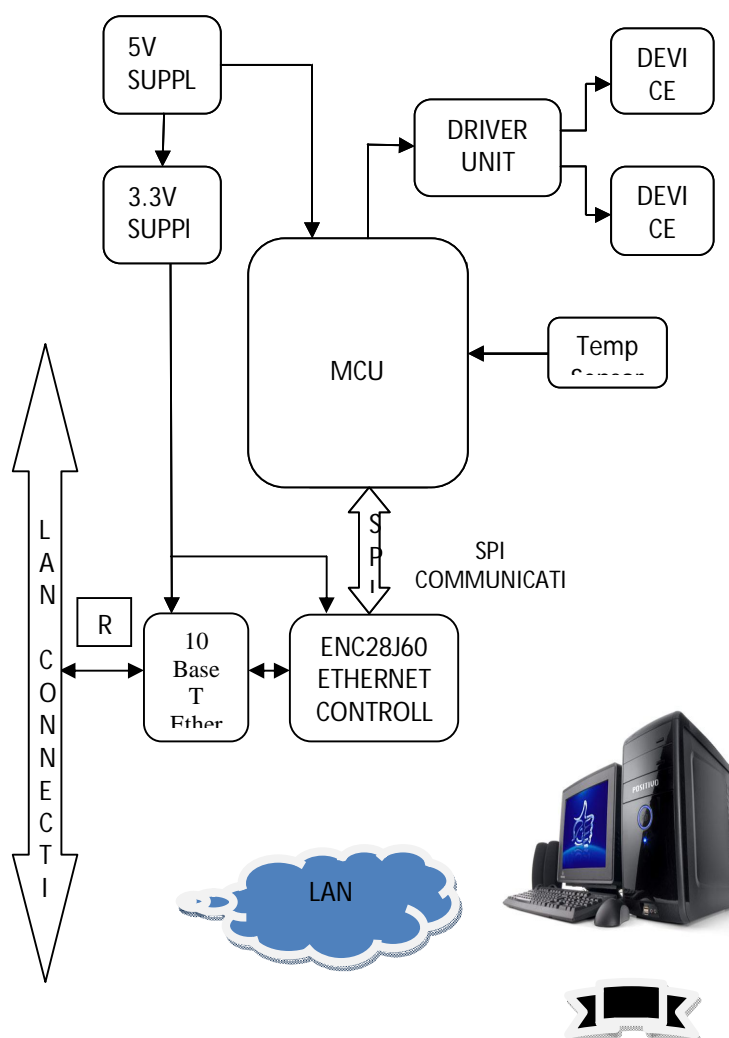

Figure 1. Module wise Block Diagram

The Micro Controller forms the central part of the design where the respective Sensors/Actuators are connected to the electronic equipments to perform the necessary functions. The Micro Controller has a JTAG interface through which it can be programmed at any point of time without affecting other components. This feature is used to change the contents of the flash memory where the web pages are stored. The Analog circuitry around the Ethernet Controller mainly consists of the isolation transformer and LEDs to indicate the status of the network link

II. METHODS

A. Overview of the System

The aim of the project is to control the devices or equipment's from the remote place through a web page. Here all the devices, which are to be controlled, are connected to the relays (acts as switches) on the web server circuit board. The web-server circuit is connected to LAN or Internet. The client or a person on the PC is also connected to same LAN or Internet. By typing the IP-address of LAN on the web browser, the user gets a web page on screen; this page contains all the information about the status of the devices. The user can also control the devices interfaced to the web server by pressing a button provided in the web page.

B. Ethernet

Ethernet is a large and diverse family of frame-based computer networking technologies for local area networks (LANs). The name comes from the physical concept of the ether. It defines a number of wiring and signaling standards for the physical layer, through means of network access at the Media Access Control (MAC)/Data Link Layer, and a common addressing format. On top of the physical layer Ethernet stations communicate to each other by sending each other data packets, small blocks of data that are individually sent and delivered.

Ethernet is standardized as IEEE 802.3. The combination of the twisted pair versions of Ethernet for connecting end systems to the network, along with the fiber optic versions for site backbones, is the most widespread wired LAN technology. It has been in use from around 1980 to the present, largely replacing competing LAN standards such as token ring, FDDI, and ARCNET. In recent years, Wi-Fi, the wireless LAN standardized by IEEE 802.11, is prevalent in home and small office networks and augmenting Ethernet in larger installations.

C. TRANSMISSION CONTROL PROTOCOL (TCP)

TCP (Transmission Control Protocol) was specifically designed to provide a reliable end-to-end byte stream over an unreliable internetwork. An internetwork differs from a single network because different parts may have wildly different topologies, bandwidths, delays, packet sizes, and other parameters. TCP was designed to dynamically adapt to properties of the internetwork and to be robust in the face of many kinds of failures.

Each machine supporting TCP has a TCP transport entity, either a library procedure, a user process, or part of the kernel. In all cases, it manages TCP streams and interfaces to the IP layer. A TCP entity accepts user data streams from local processes, breaks them up into pieces not exceeding 64 KB (in practice, often 1460 data bytes in order to fit in a single Ethernet frame with the IP and TCP headers), and sends each piece as a separate IP datagram. When datagrams containing TCP data arrive at a machine, they are given to the TCP entity, which reconstructs the original byte streams. For simplicity, we will sometimes use just "TCP" to mean the TCP transport entity (a piece of software) or the TCP protocol (a set of rules). From the context it will be clear which is meant. For example, in "The user gives TCP the data," the TCP transport entity is clearly intended. The IP layer gives no guarantee that datagrams will be delivered properly, so it is up to TCP to time out and retransmit them as need be. Datagrams that do arrive may well do so in the wrong order; it is also up to TCP to reassemble them into messages in the proper sequence. In short, TCP must furnish the reliability that most users want and that IP does not provide.

The layout of a TCP segment. Every segment begins with a fixed-format, 20-byte header. The fixed header may be followed by header options. After the options, if any, up to $65,535 - 20 - 20 = 65,495$ data bytes may follow, where the first 20 refer to the IP header and the second to the TCP header. Segments without any data are legal and are commonly used for acknowledgements and control messages.

D. Internet protocol (IP)

An appropriate place to start our study of the network layer in the Internet is the format of the IP datagrams themselves. An IP datagram consists of a header part and a text part. The header has a 20-byte fixed part and a variable length optional part. It is transmitted in big-endian order: from left to right, with the high-order bit of the Version field going first. (The SPARC is big endian; the Pentium is little-endian.) On little endian machines, software conversion is required on both transmission and reception

E) IP Addresses

Every host and router on the Internet has an IP address, which encodes its network number and host number. The combination is unique: in principle, no two machines on the Internet have the same IP address. All IP addresses are 32 bits long and are used in the Source address and Destination address fields of IP packets. It is important to note that an IP address does not actually refer to a host. It really refers to a network interface, so if a host is on two networks, it must have two IP addresses. However, in practice, most hosts are on one network and thus have one IP address.

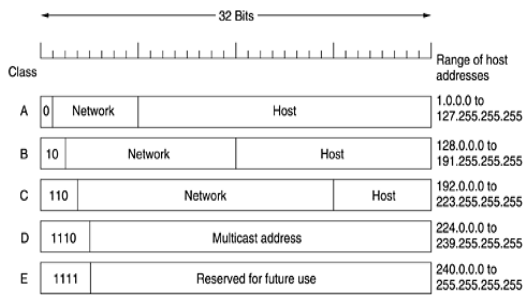

Fig 2. IP address

For several decades, IP addresses were divided into the five categories listed in Fig. 2. This allocation has come to be called glassful addressing. It is no longer used, but references to it in the literature are still common. We will discuss the replacement of glassful addressing shortly

F)HYPERTEXT TRANSFER PROTOCOL (HTTP)

The transfer protocol used throughout the World Wide Web is HTTP (Hypertext Transfer Protocol). The HTTP is an application level protocol. It is a generic, stateless, object oriented protocol that can be used for many tasks, such as name servers and distributed object management systems, through extension of its request methods (commands). It uses a client-server relationship and is based on a stream-oriented transport layer, such as TCP. Today, the most important use is transferring HTML documents with multimedia contents between Internet servers and clients (WWW). It works with the principle of request and response. The simplest case is that a client establishes a connection to a server and requests a content referred by a Uniform Resource Identifier (URL) that specifies the path and name of the resource. Commonly, this is done by navigating with the web browser. These URLs are structured like a tile path. After decoding the request, the server starts transferring the resource to the client. The requests (also called methods) are sent as simple ASCII strings with a trailing carriage return (CR) and line feed (LF). The response from a server contains some header lines. Each one has a CR and LF at its end. An additional CR and LF at the end of the last line of the header indicate that the data is following. In most cases, this will be an HTML page or a picture file. After

transferring the content, the connections usually closed again

G) Ethernet 10Base-T (10-Mbps)

10Base-T provides Manchester-encoded 10-Mbps bit-serial communication over two unshielded twisted-pair cables. Although the standard was designed to support transmission over common telephone cable, the more typical link configuration is to use two pair of a four-pair Category 3 or 5 cable, terminated at each NIC with an 8-pin RJ-45 connector (the MDI), as shown in Fig 5 Because each active pair is configured as a simplex link where transmission is in one direction only, the 10Base-T physical layers can support either half-duplex or full-duplex operation.

The Typical 10Base-T Link Is a Four-Pair UTP Cable in Which Two Pairs Are Not Used

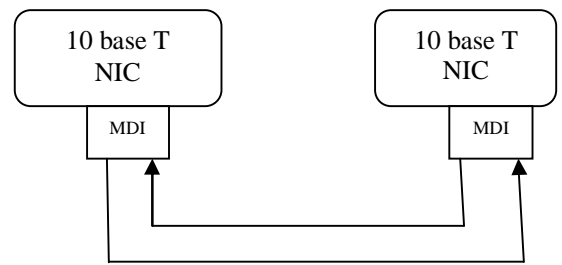

Four -pair category 3 or 5 UTP cable

Fig 3 The Typical 10Base-T Link

Although 10Base-T may be considered essentially obsolete in some circles, it is included here because there are still many 10Base-T Ethernet networks, and because full-duplex operation has given 10BaseT an extended life. 10Base-T was also the first Ethernet version to include a link integrity test to determine the health of the link. Immediately after powerup, the PMA transmits a normal link pulse (NLP) to tell the NIC at the other end of the link that this NIC wants to establish an active link connection: If the NIC at the other end of the link is also powered up, it responds with its own NLP. If the NIC at the other end of the link is not powered up, this NIC continues sending an NLP about once every 16 ms until it receives a response. The link is activated only after both NICs are capable of exchanging valid NLPs.

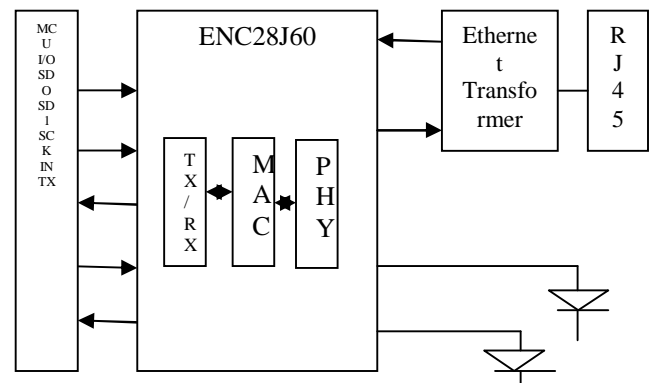

Fig 4 Interfacing of ENC28J60

H)DRIVE CIRCUIT AND PROTECTION DIODES FOR RELAYS

1)The coil of a relay passes a relatively large current, typically 30mA for a 12V relay, but it can be as much as 100mA for relays designed to operate from lower voltages. Hence a CB amplifier is used to achieve the current rating of the relay.

Transistors and ICs must be protected from the brief high voltage produced when a relay coil is switched off. The diagram shows how a signal diode (e.g. 1N4148) is connected 'backwards' across the relay coil to provide this protection.

Current flowing through a relay coil creates a magnetic field which collapses suddenly when the current is switched off. The sudden collapse of the magnetic field induces a brief high voltage across the relay coil which is very likely to damage transistors and ICs. The protection diode allows the induced voltage to drive a brief current through the coil (and diode) so the magnetic field dies away quickly rather than instantly. This prevents the induced voltage becoming high enough to cause damage to transistors and ICs.

I)Circuit details

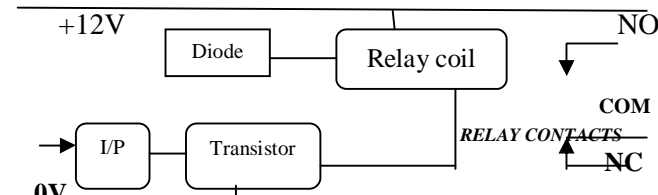

Fig 5 Drive circuit and protection diodes for relays

Ethernet is the most common Local Area Network (LAN) technology in use today. On top of the Physical Layer Ethernet stations communicate to each other by sending data packets. Each Ethernet station a given a single 48-bit MAC address, which is used both to specify the destination and the source of each data packet. As with other IEEE 802 LANs, each Ethernet station is given a single 48-bit MAC address, which is used both to specify the destination and the source of each data packet. Network interface cards (NICs) or chips normally do not accept packets addressed to other Ethernet stations. Adapters generally come programmed with a globally unique address but this can be overridden either to avoid an address change when an adapter is replaced or to use locally administered addresses. Serial Ethernet Board has 28-pin ENC28J60 10Base-T Controller with on board Media Access Control and Physical layer, 8KB of buffer RAM and Serial Peripheral Interface (SPI) communication

J)Flow chart

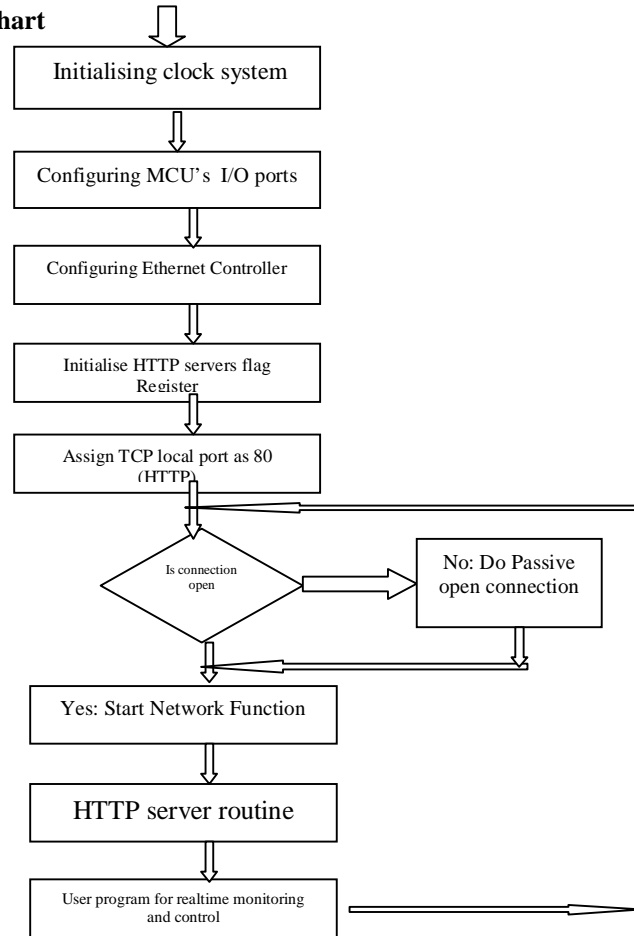

Fig 6 Flow chart design

Every web server has a unique address so that other computers connected to the internet know where to find it on the vast network. The IP (Internet Protocol) address looks something like this: 69.93.141.146. Web hosts rent out space on their web servers to people or businesses to set up their own websites. The web server allocates a unique website address to each website it hosts. When you connect to the internet, your personal computer also receives a unique IP address assigned by your ISP (internet service provider). This address identifies your computer's location on the network. When you click on a link to visit a website, like www.wisegeek.com, your browser sends out a request to wise Geek's IP address. This request includes return information and functions like a postal letter sent across town, but in this case the information is transferred across a network. The communiqué passes through several computers on the way to wise GEEK, each routing it closer to its ultimate destination.

When your request reaches its destination, the web server that hosts wise Geek's website sends the page in HTML code to your IP address. This return communiqué travels back through the network. Your computer receives the code and your browser interprets the

HTML code then displays the page for you in graphic form.

The more powerful the server, the faster it can serve up website pages. Slower, smaller servers may result in frustrating lag time for viewers. High traffic can also slow servers that are not powerful enough to handle high volumes of data exchange. This lag time should be a concern if you are shopping for a web host. Most web hosts have a page dedicated to sharing technical information about their web server, including speed, capacity, network configuration and other details.

In theory, web servers stay connected to the Internet 24/7, 365 days a year. In truth they experience occasional downtime due to maintenance and technical problems. Web servers with consistent records of an uptime of 99.5% or better are considered reliable.

III. CONCLUSION

Embedded web servers are an integral part of an embedded network. Embedded Servers in our project can be used to change the status of the various Gadgets connected to the kit by means of Internet.

THE EMBEDDED WEB SERVER DESIGN INCLUDES A COMPLETE WEB SERVER WITH TCP/IP SUPPORT AND ETHERNET INTERFACE. IT PROVIDES THE SOFTWARE FOR AUTOMATIC CONFIGURATION OF THE WEB SERVER IN THE NETWORK. THE EMBEDDED WEB SERVER REFERENCE DESIGN INCLUDES COMPLETE SOURCE CODE WRITTEN IN C-LANGUAGE. A COMPREHENSIVE MODEL OF THE EMBEDDED WEB SERVER HAS BEEN DESIGNED USING PIC. WE CAN REDUCE THE POWER CONSUMPTION BY MAKING USE OF A DIFFERENT KIND OF MICROCONTROLLER CALLED THE AVR, WHICH MAKES USE OF ONLY 3.3V POWER SUPPLY. OUR DESIGN IS A QUICK START TO EMBEDDED WEB SERVERS

REFERENCES

REFERENCES

[1] Yu-Lung Ke, and Ying-Chun Chuang. A Novel Single-Stage Power-Factor-Correction Circuit With High-Frequency Resonant Energy Tank for DC-Link Inverters. IEEE Transactions on Circuits and Systems—II: Express Briefs, Vol. 53, no. 2, FEBRUARY 2006, pp.115-119

[2] Qun Zhao, Fengfeng Tao, Peng Xu. Improved Performance of Continuous Current Mode Boost Converter for Power Factor Correction. Proc. of APEC97 □ pp.266-271

[3] Data Sheet SJA1000, Philips Semiconductors

[4] Jöhnk, E. and Dietmayer, K.: Determination of Bit Timing Parameters for the CAN Controller SJA1000, Application Note AN97046, Philips Semiconductors, 1997

[5] Hank, P.: PeliCAN: A New CAN Controller Supporting Diagnosis and System Optimization, 4th International CAN Conference, Berlin, Germany, October 1997

[6] Wang Xinyu □ Zhang Jing □ and Ye Jiazhuo □ □ Study on Energy Acquisition and Billing Automation System,” Computer engineering and application □ pp.240-243 June 200, pp.240-243.

[7] Wu Zaijun □ Wang Zheng □ and Hu Minqing □ □ Implementation of Concentralized Automatic Meter Reading Apparatus and Research on its Communication,” Power System Technology □ February 2002, pp.44-47.

[8] Sung-Jin Choi, Kyu-Chan Lee and BoHyung Cho. Design of Fluorescent Lamp Ballast With PFC Using a Power Piezoelectric Transformer. IEEE Transactions on Industrial Electronics, Vol. 52 ,no .6, DECEMBER 2005, pp.1573-1581.

[9] Ching Jung Chen, Lin Chen. Passive Lossless Snubber Soft DC/DC Converter. Proc. of APEC98 □ PP.1049-1054.

[10] FAN Yizhi. “Visual Basic and RS-232 serial communication control,” .Beijing:chinese Young People Press. July 2002. pp.126-128.

[11] www.atmel.com/dyn/resources/prod_documents/doc1919.pdf

[12] www.atmel.com/dyn/resources/prod_documents/doc0336.pdf

[13] www.clare.com/home/pdfs.nsf/www/M8870-R3.pdf/sfile/M8870-R3.pdf

[14] LAN Isolation Transformer Catalog. Pulse.

[15] Ethernet Technologies. Cisco Systems

[16] Ethernet Controller Technical Reference Manual. Cirrus Logic Inc

[17] Transmission Control Protocol by Postel,

[18] Internet Protocol (IP) by Postel J