

Original Article

Detecting Glucose Level using IR Sensor

Dr. R Kavitha¹, M.S. Janani², K Dhanalakshimi³

¹ Professor, Dept. of Information Technology (IT) from Velammal College of Engineering and Technology (VCET), Viraganoor, Madurai, India

^{2,3} B.Tech (IT) from Velammal College of Engineering and Technology (VCET), Viraganoor, Madurai, India

Abstract - Diabetes Mellitus ubiquity has been spiked, and it has grown as a major World Wide problem. As per a report by the Indian Diabetic Association, about 63 million people have diabetes, which is likely to go up to 80 million by 2025. It is a very serious problem that even leads to death. Diabetes is a chronic disease that leads to hyperglycemia, which leads to a serious problem by affecting the blood and other body parts, and causes even death. Diabetes could be identified by blood glucose level measurement. This paper's main goal is to monitor the glucose level by the non-invasive method continuously. The existing Blood pricking method is used to detect the glucose level, which is harmful and inconvenient to the patients and leads to blood loss and mental illness. A smart Device is proposed to monitor the Blood Glucose of a person without harm. The IR pair sensor is used to sense the patient's glucose level by the IR transmitter and the IR receiver. It senses the blood glucose level every 7 seconds. The Smart Device for glucose monitoring is mainly based on IR Sensor, Node MCU, Arduino IDE, LCD, Cloud, and Mobile Application. The result will be displayed in the LCD and mobile application, and the device can be used at any time and place using the Internet.

Keywords - Diabetes Mellitus, Glucose, Blood pricking, Cloud, Chronic disease, IR sensor, Node MCU, Arduino IDE, LCD, Mobile application.

I. INTRODUCTION

Diabetes is a major challenge of this current decade. It is a non-communicable disease. As per a report by the Indian Diabetic Association, about 63 million people have diabetes, which is likely to go up to 80 million by 2025. Diabetes people check their blood glucose levels more than two times per day. Hence they are inconvenienced every time. They are suffering from the danger of infection by pricking blood in the finger. Also, this method may expense associated with strips, and Lancets are more because each test requires a new test strip and Lancets. Diabetes Mellitus is considered one of the major death contributors in non-contagious diseases. The current method uses the self-monitoring glucose meter. These methods are invasive. The disadvantage of this method is that extracting the blood from the

Body and doing chemical analysis. It also gives pain and discomfort due to the patients' frequent finger pricks. Non-invasive techniques are more useful and user-friendly. It reduces the costs, and other difficulties include mental and physical pain, which involves the invasive method of glucose determination. Researchers can still not overcome many drawbacks of the invasive glucose monitoring method. The problem includes the scanning pressure that must be applied, physiological differences such as the width of tissues, correlation error, hardware sensitivity, and stability [2]. The proposed technique uses a near-infrared sensor to transmit and receive rays from the forearm. The glucose level can be predicted by analyzing the intensity variation in the received signal using a photodetector on another side. Then the data can be transmitted to a remote android device for further analysis. An easy and pain-free method of measuring blood glucose concentrations will inform the doctors and patients by monitoring the glucose level.

II. METHODOLOGY

To develop a non-invasive method for measuring blood glucose concentration levels. Such a method would be pain-free and, therefore, possibly more desirable amongst a larger population for use with continuous health monitoring. The solution would be using near-infrared light to measure blood glucose concentration levels [5]. Hence it would not require tedious amounts of test strips for each measurement. Common people may easily recommend and use it to monitor their day-to-day health.



A. Block Diagram

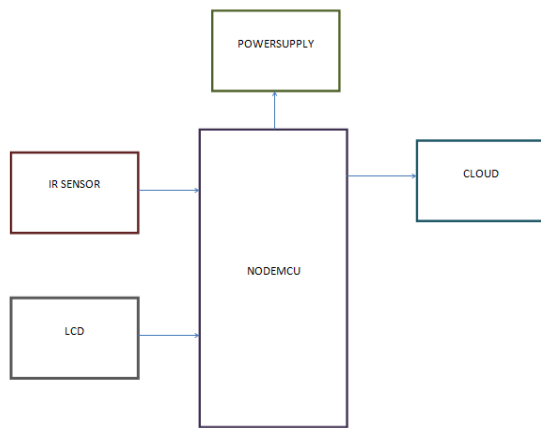

B. Hardware's

1) IR Sensor

Sensors are the electric device used to sense the changes that occur in the body and the environment. The change includes the pigmentation color, temperature, humidity, sound, etc. They sense the changes that occurred and notify accordingly. In an IR sensor, there is an emitter and detector. The emitter emits the IR rays, detecting them [5]. The IR sensor consists of three components for its function it includes,

- IR LED (emitter)
- Photodiode (detector)
- Op-Amp

1(a) IR Led:

It is the light-emitting diode that emits IR radiation. The function of the emitter is to convert electrical energy into light energy. It works by the principle of recombination of the electron-hole pair.

1 (b) Photodiode:

It is a p-n junction diode connected in the reverse bias direction. The function of this detector is to convert light into electrical energy. It works effectively only when a certain amount of light or photon falls on it. If there is no falling light on the photodiode, it has infinite resistance and acts as an open switch.

1(c) Op-Amp:

Op-Amp Operational amplifier is the simplified form of Op-Amp. It performs many operations such as addition, subtraction, multiplication, division, etc. The Op-Amp is a DC-coupled high gain amplifier with two inputs and a single output.

2) Node MCU

The Node MCU is open source software and hardware development environment which contains the ESP8266 Wi-Fi Module that can give any microcontroller access to the Wi-Fi network. The

embedded C code is inserted into the node MCU using the port connection. The diagrammatic representation of Node MCU with Pin connections and its descriptions are given below.

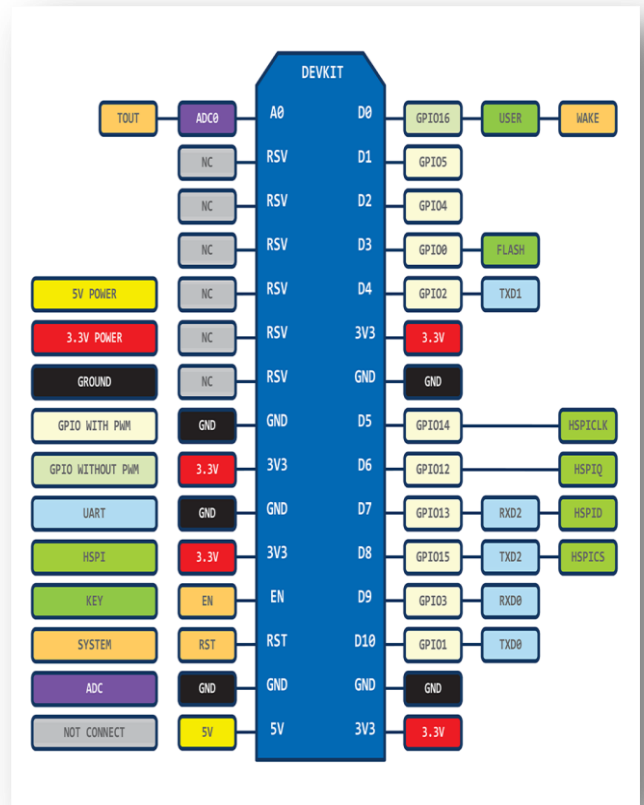

3) LCD

LCD stands for Liquid Crystal Display. It is a small thin, flat panel (normally 16*2) used for electronically displaying information. The LCD screen consists of two lines with 16 characters each. Each character consists of a 5*7 matrix. The contrast on display depends on the power supply voltage and whether messages are displayed in one or two lines. The below diagram is a sample display of an LCD board.



4) Power supply

A rectifier's job is to convert an Alternating Current (AC) to Direct Current (DC) and gives the desired output. Rectifiers are used in the power supplies to provide the necessary DC voltage for the electric components or the devices. They are made with four or more diodes or other controlled solid switches. The below diagram describes the working

function of the rectifier when connected to the power supply.

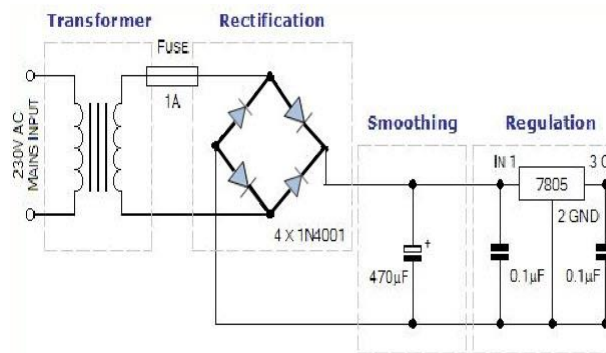

C. Softwares

1) Arduino IDE

The Arduino IDE is an open-source hardware design and software SDK. It functions similarly to the Node MCU. The Arduino hardware includes the micro-controller board with ready USB connector pins, LED lights, and the standard data pins. It also defines standard interfaces to interact with sensors or other boards. The Arduino board also has CPU chips (ARM or Intel x 86 chips) with memory chips and various programming environments. There is an Arduino reference design for the ESP8266 chip as well. However, the flexibility of Arduino also means significant variations across different vendors. Here Arduino IDE is used to embed the C program into Node MCU using the port connection.

2) Application

The Mobile application is made with the help of PHP and MySQL using Xampp, and then it is converted into the application using Android studio. The cloud is used for storing the data values, and it also shows a graphical view of the data's

III. WORKING

When the supply is given to the IR sensor via the transformer, resistor, capacitor, and diodes, the LED emits light radiations. If the surface is white, then it reflects all the radiations. The white surface reflects all the radiations, whereas the black color absorbs them. As these radiations start falling on the photodiode connected in reverse bias, the resistance of the photodiode starts decreasing rapidly, and the voltage drop across the diode also decreases. The voltage at Pin 3 starts to increase, and as it reaches just beyond the voltage of Pin 2, the comparator gives high output. On the black surface, even though the LED emits light, it is not reflected. Hence the photodiode doesn't detect anything, and its resistance will be infinity. So the comparator will give a low output. Here, the IR sensor emits the light every seven seconds, and the readings are calculated and displayed in both LCD and Mobile Applications. The

diagram shows the working strategy of the IR sensor and photodiode.

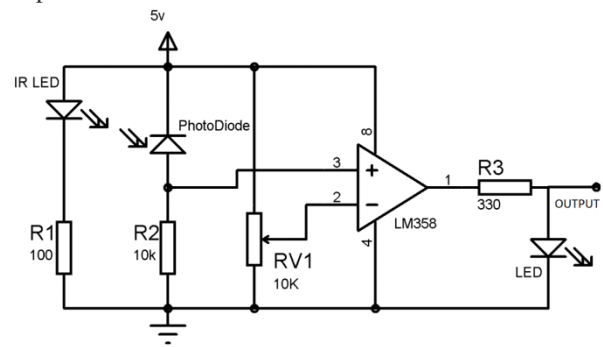

IV. RESULT AND DISCUSSION

The desired prototype system is designed and developed to detect blood glucose levels using the Non-invasive IR technique. The result was approximate when compared with the pricking methodology.

V. OUTPUT

A. LCD Output



B. Mobile Application Output

1) READINGS

Health Readings		
S.NO	GLUCOSE	DATE
1	70	2019/03/02
2	70	2019/03/02
3	85	2019/03/02
4	85	2019/03/02
5	74	2019/03/02
6	77	2019/03/02
7	85	2019/03/02
8	82	2019/03/02

2) CHART



Highest Value

85

Lowest value

0

3) Comparison Result (Pricking & Device Outputs)

Patients Name	Glucose Analysis	
	Pricking Method	Device
MANI S	102	87
VELMURUGAN K	94	73
SUMITHA R	97	75
ESWARAN N	105	87
KASI M	80	70

C. Device

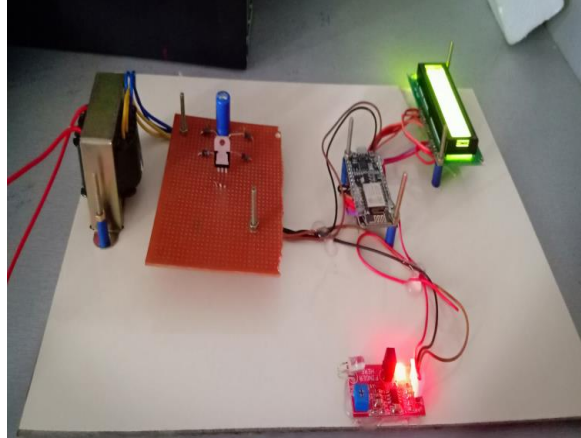

VI CONCLUSION

Early detection of glucose levels and control of disease is necessary. Our approach to monitoring glucose levels is healthier than the invasive approach. The obtained result shows the glucose level in blood by the non-invasive method. Glucose levels were analyzed, and results were obtained approximately. Also, this information can be sent to a doctor for further analysis.

REFERENCES

- [1] Simon C.H. Lam, Joanne W.Y. Chung, K.L. Fan, and Thomas K.S. Wong School of Nursing, The Hong Kong Polytechnic University, Hong Kong "Invasive blood glucose measurement by near-infrared spectroscopy: Machine drift, Time drift, and physiological effect"(China-2010)
- [2] Parag Narkhede, Suraj Dhal war and B. Karthikeyan, "NIR Based Noninvasive Blood Glucose Measurement" 2016
- [3] Tuan Nguyen Gia, Mai Ali, Imed Ben Dhaou, Amir M. Rahmani, Tomi Westerlund, Pasi Liljeberg, "IoT- based continuous glucose monitoring system: A feasibility study" 2017
- [4] Megha C.Pande, Prof. A. K. Joshi "Non-invasive Glucometer using optical method" (International Journal of Engineering Research and Applications (IJERA) ISSN: 2248-9622 www.ijera.com Vol. 3, Issue 4 Jul- Aug 2013
- [5] Saina Sunny, S.Swapna Kumar "Optical Based Non-Invasive Glucometer with IoT," 14 June 2018
- [6] R.A.Buda and M. Mohd.Addi "A Portable Non Invasive Blood Glucose Monitoring Device" December 2014
- [7] Shyqyri Haxha and Jaspreet Jhoja "Optical Based Non-invasive Glucose Monitoring Sensor Prototype"
- [8] A.Trabelsi, M. Boukadoum, C. Fayomi, E.M. Aboulhamid "Blood Glucose Sensor Implant Using NIR Spectroscopy: Preliminary Design Study"
- [9] P.Sampath Reddy and K. Jyostna "Development of Smart Insulin Device for Non Invasive Blood Glucose Level Monitoring" 2017
- [10] K.A.Unnikrishna Menon, Deepak Hemachandran, Abishek Thekkeyil Kunnath "Voltage Intensity Based Non-Invasive Blood Glucose Monitoring"