

# IOT Based Vacuum Cleaner Robot

Sutendra Subash Mahale<sup>1</sup>, Aparna Rane<sup>2</sup>, Vaishnavi Malvanker<sup>3</sup>

Department of Computer Engineering  
Agnelganv Verna Goa 403722

**Abstract**— Today Robots are excessively used in every field namely household, hotels, offices etc. Due to growing demand for automation, we are proposing an automatic and manual IOT based vacuum cleaning robot. In the market, various robots are available but their high price and low versatility are the main cons that hold back selling rates. The aim in implementation of this model is to build a cost efficient, low maintenance, and user-friendly robot that can perform dry vacuum cleaning. It operates on two modes namely automatic and manual. This vacuum cleaning robot is capable of sucking the dust, obstacle detection and scheduling the cleaning work through android application. This robot will help handicapped people to clean their house without any external help. Arduino Uno and node MCU control all software and hardware operation of the vacuum cleaner robot.

**Keywords** — Robot Cleaning, Vacuum, Dry, Floor, Lifestyle

## I. INTRODUCTION

Since today's household are becoming smarter and automated, cleaning of floor is way more important for our health purpose and replacing mops with robots also reduces work force. Although conventional vacuum cleaner are cost effective to some extent, the large mechanical and electrical parts are expensive and power consuming. Whereas IOT based vacuum cleaning robot can operate on low power consuming mechanical and electrical parts.

The main aim in implementation of this model is to build a vacuum cleaning robot, which will be cost effective, less noisy, lightweight and requiring low Maintenance and will provide for a modern process for cleaning the floor using the IOT app. Having the facility of obstacle detection, it will prevent the robot from bumping into walls and furniture. Ultrasonic sensor will be used for obstacle detection. IOT based vacuum cleaning robot also has a global app, which can control the robot in Manual mode as well as it can schedule the cleaning activity using internet connectivity.

## II. LITRATURE SURVEY

Recently there are many innovative vacuum cleaners in the market. [1] Proposes "A smart floor cleaner robot using android" model using Bluetooth module, Wi-Fi module and android app using MIT app inventor. A limitation of this model was its use of Bluetooth, which limited the vicinity and some

limited functionalities provided through the MIT inventor app.

"Abhishek Pandey in [2]" proposed a model, which is autonomous, and it has infrared sensor to detect the obstacle. This implementation was only limited to automatic mode and did not allow movement of the robot manually.

To overcome the drawbacks of existing system we plan to develop a robot based on ATmega328. This model works in two modes namely: Automatic mode and Manual Mode which is controlled by Node MCU and an android phone..

## III. BLOCK DIAGRAM

The heart of this model is Arduino Uno. The other essential components include node MCU, sensors and motor assembly, which interact with each other as shown in block diagram.

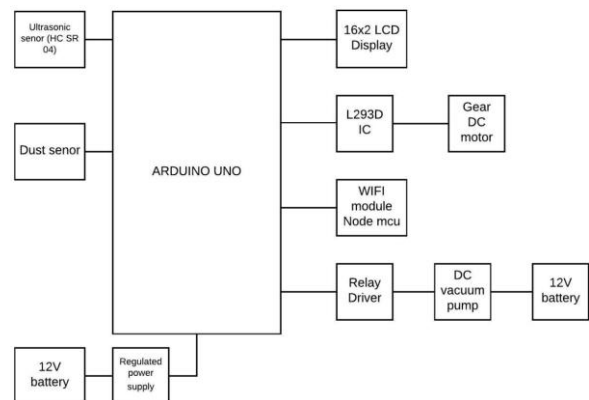

## IV. WORKING

For cleaning purpose, application model will be provided with the vacuum pump, which will suck the dust. The model also avoids bumping in to walls and furniture through the usage of ultrasonic sensor. Ultrasonic sensor facilitates change in robot direction when it detects an obstacle.

The model is fitted with dust sensor. The Node MCU will help Android application to connect over internet by which you can control the robot manually and can schedule it for cleaning activity.

Finally, 12V battery supply is given to power on the circuit.

## V. MODEL FUNCTIONALITY

The Android application has four main buttons namely vacuum (ON/OFF) to switch on the vacuum pump, Robot (ON/OFF) to switch on the Robot circuitry. Above mentioned buttons have dedicated relays, which will be active as an when particular event occurs. Schedule button is used to schedule the cleaning work, climb - to climb the stairs, which is kept as future work.

It also has navigation button namely forward, back, right and left. Other buttons which are present are set time, start, stop and exit.

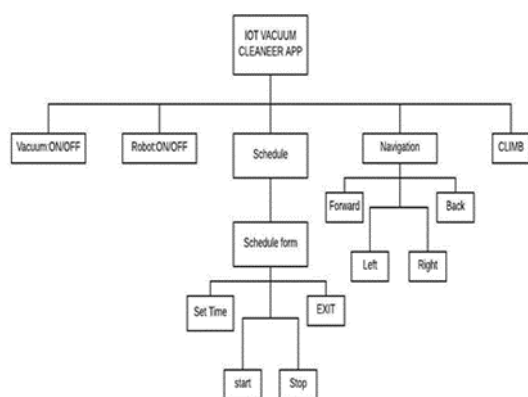

## VI. MECHANICAL DESIGN

Mechanical design is made up of chassis, vacuum cleaner and dirt collector.

Chassis: It is designed of wooden board in rectangle shape with dimension of length and breadth 30 cm and 22 cm respectively, where all the components of the model will be mounted.

Vacuum cleaner and dirt collector: The vacuum pump nozzle is fitted with dirt collector which is made up of plastic bottle.

## VII. CONCLUSIONS

The model developed is more versatile and cost efficient. As it has scheduling feature which is being operated by android application makes the model more user friendly. Automatic mode could also help disabled people having mobility issues to use the model for cleaning without any external help. This model can be used in homes to save time and enhance the lifestyle. It can also be improved further to make it useful in industries and factories too.

## REFERENCES

[1] Smart Floor Cleaning Robot Using Android Puneet Kaushik<sup>1</sup> , Mohit Jain<sup>2</sup> , Gayatri Patidar<sup>3</sup> ,Paradayil Rhea Eapen<sup>4</sup> , Chandra Prabha Sharma<sup>5</sup> 1234 Department of ECE, Institute of Technology, Nirma University, Ahmedabad, India 5 Department of CSE, Rajasthan Technical University, Kota, India

International Journal of Electronics Engineering (ISSN: 0973-7383) Volume 10

[2] A Technological Survey on Autonomous Home Cleaning Robots Abhishek Pandey ,Anirudh Kaushik, Amit Kumar Jha, Girish Kapse International Journal of Scientific and Research Publications, Volume 4, Issue 4, April 2014 1 ISSN 2250-3153

[3] Automatic Sanitary Robot with Optimized Performance of Arbitrary Track Selection using PIC Micro-controller Jayasudha. A , Kalaiselvi. A , S. Dinesh kumar , S. Sathiyavathi , A. Subha, M.Sabariprasath IJSART - Volume 2 Issue 1 –JANUARY 2016

[4] “Design and Development of Floor Cleaner Robot (Automatic and Manual) Manreet Kaur, Mohali Preeti Abro “International Journal of Computer Applications (0975 – 8887) Volume 97– No.19, July 2014

[5] "Achieving Artificial Intelligence through Building Robots." Boston: Massachusetts Institute of Technology, 1986.

[6] Mark Yim, David G. Duff, and Kimon D. Roufas. "PolyBot: a Modular Re-configurable Robot." IEEE International Conference on Robotics & Automation. April 2000.

[7] Smart floor Cleaning robot By Nikita Prashar, Tejashree Thorat, Abhishek Galande & Ritesh Durande, Global journal of computer science and Technology Volume 12 Issue 3 Version 1.0 February 2012